

N2 W6 A 1,7_m

AS-BLB.J

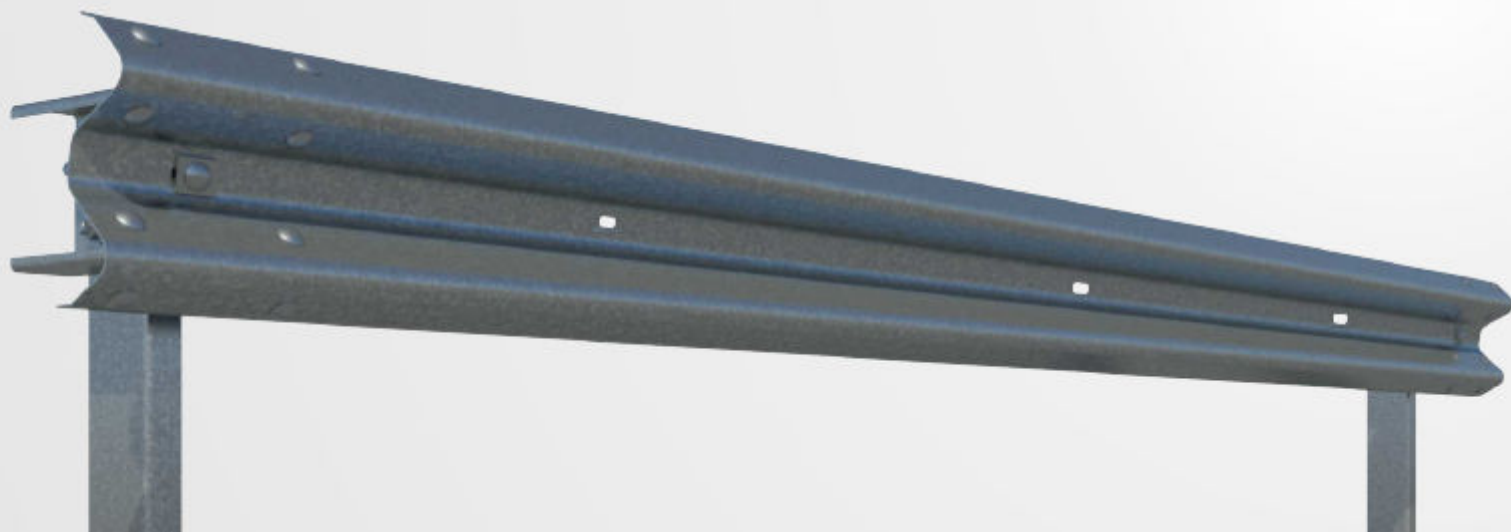

CE



asebal

Vehicle Restraint System

Definition

Single metal barrier for lateral side. System formed by double wave barrier, spacer and tubular posts 4 metres apart. This system can be installed with either a 2.5 m thick barrier or a 2 mm thick barrier

Performance parameters

Containment level	N2	Working width (W)	W6	Impact Severity	A	Dynamic Deflection (D)	1,7_m
-------------------	-----------	-------------------	-----------	-----------------	----------	------------------------	------------------------

Profile

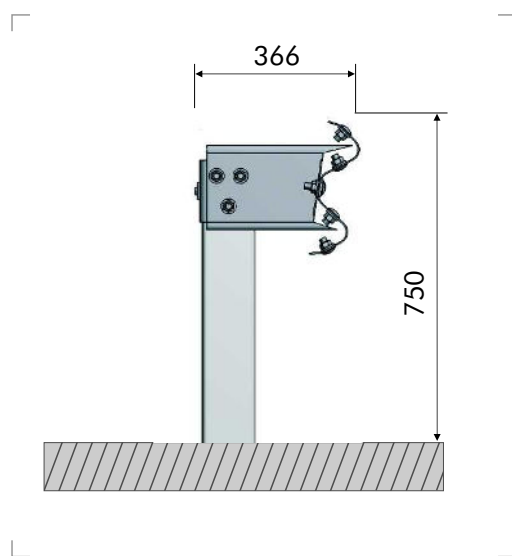

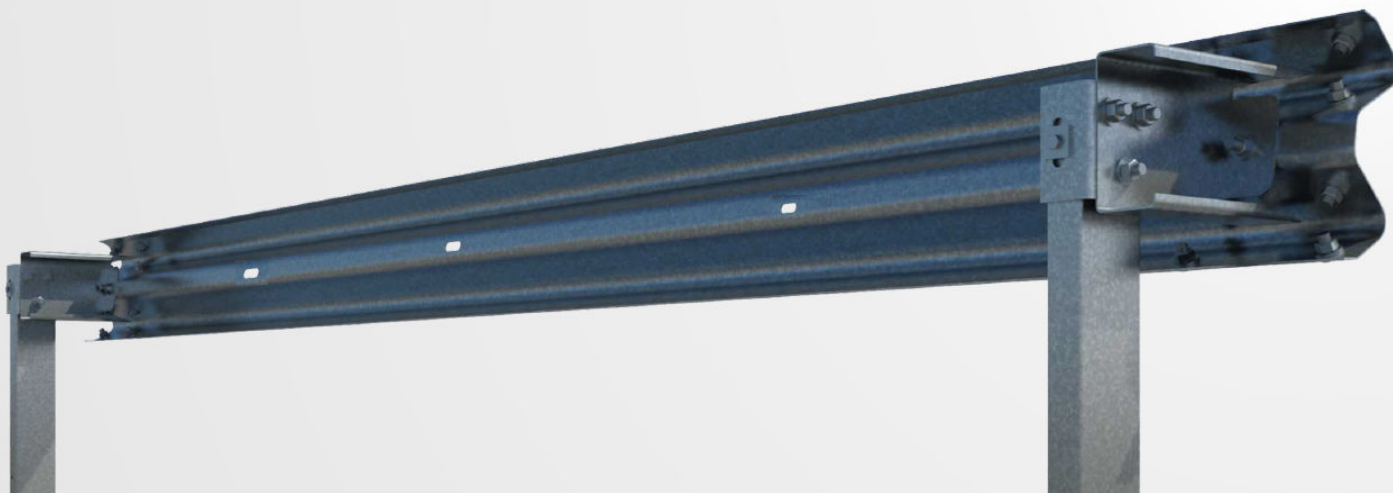

Components for sections of 4 m

Item	Part	Uds
1	Standard barrier of 4 m (2.5 or 2.0 mm thick)	1
2	Tubular post of 1,500 mm	1
3	Standard spacer	1
4	Modified connector for spacer	1
5	Bolt M16x40, with nut	1
6	Bolt M16x35, with nut	3
7	Bolt M16x30, with nut	8
8	Bolt M10x40	2
9	M10 nut	2
10	Washer 40x40x5 mm	2
11	Washer 40x33x5 mm	2
12	Rectangular washer 55x40x5 mm	1
13	Washer Ø17x35x4 mm	12
14	Reflector	0,5

Fasteners

